

9 Transportation and Assignment Problems

We will now consider several special cases of the minimum cost flow problem: the transportation problem, the assignment problems, the maximum flow problem, and the shortest path problem.

9.1 The Transportation Problem

In the *transportation problem* we are given a set of *suppliers* $i = 1, \dots, n$ producing s_i units of a good and a set of *consumers* $j = 1, \dots, m$ with demands d_j such that $\sum_{i=1}^n s_i = \sum_{j=1}^m d_j$. The cost of transporting one unit of the good from supplier i to consumer j is c_{ij} , and the goal is to match supply and demand while minimizing overall transportation cost. This can be formulated as an uncapacitated minimum cost flow problem on a *bipartite network*, i.e., a network $G = (S \uplus C, E)$ with $S = \{1, \dots, n\}$, $C = \{1, \dots, m\}$, and $E \subseteq S \times C$. As far as optimal solutions are concerned, edges not contained in E are equivalent to edges with a very large cost. We can thus restrict our attention to the case where $E = S \times C$, known as the *Hitchcock transportation problem*:

$$\begin{aligned} & \text{minimize} && \sum_{i=1}^n \sum_{j=1}^m c_{ij} x_{ij} \\ & \text{subject to} && \sum_{i=1}^n x_{ij} = d_j \quad \text{for all } j = 1, \dots, m \\ & && \sum_{j=1}^m x_{ij} = s_i \quad \text{for all } i = 1, \dots, n \\ & && x_{ij} \geq 0 \quad \text{for all } i, j. \end{aligned}$$

It turns out that transportation problems already capture the full expressiveness of minimum cost flow problems.

THEOREM 9.1. *Every minimum cost flow problem with finite capacities or non-negative costs has an equivalent transportation problem.*

Proof. Consider a minimum cost flow problem on a network $G = (V, E)$ with supplies or demands b_i , capacities \underline{m}_{ij} and \overline{m}_{ij} , and costs c_{ij} . When constructing an initial feasible tree solution in the previous lecture, we saw that we can assume without loss of generality that $\underline{m}_{ij} = 0$ for all i, j . We can further assume that all capacities are finite: if some edge has infinite capacity but costs are non-negative then setting the capacity of this edge to a large enough number, for example $\sum_{i \in V} |b_i|$, does not affect the optimal solution of the problem.

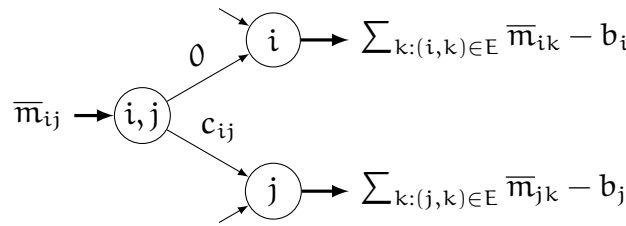

Figure 9.1: Representation of flow conservation constraints by a transportation problem

We now construct a transportation problem as follows. For every vertex $i \in V$, we add a sink vertex with demand $\sum_k \bar{m}_{ik} - b_i$. For every edge $(i, j) \in E$, we add a source vertex with supply \bar{m}_{ij} , an edge to vertex i with cost $c_{ij,i} = 0$, and an edge to vertex j with cost $c_{ij,j} = c_{ij}$. The situation is shown in Figure 9.1.

We now claim that there exists a direct correspondence between feasible flows of the two problems, and that these flows have the same costs. To see this, let the flows on edges (ij, i) and (ij, j) be $\bar{m}_{ij} - x_{ij}$ and x_{ij} , respectively. The total flow into vertex i then is $\sum_{k:(i,k) \in E} (\bar{m}_{ik} - x_{ik}) + \sum_{k:(k,i) \in E} x_{ki}$, which must be equal to $\sum_{k:(i,k) \in E} \bar{m}_{ik} - b_i$. This is the case if and only if $b_i + \sum_{k:(k,i) \in E} x_{ki} - \sum_{k:(i,k) \in E} x_{ik} = 0$, which is the flow conservation constraint for vertex i in the original problem. \square

9.2 The Network Simplex Method in Tableau Form

When solving a transportation problem using the network simplex method, it is convenient to write it down in a tableau of the following form, where λ_i for $i = 1, \dots, n$ and μ_j for $j = 1, \dots, m$ are the dual variables corresponding to the flow conservation constraints for suppliers and consumers, respectively:

| | | | | |
|-------------|--|--|--|----------|
| | μ_1 | \dots | μ_m | |
| λ_1 | x_{11} c_{11} | \dots \dots | x_{1m} c_{1m} | s_1 |
| \vdots | \vdots \vdots | \ddots \ddots | \vdots \vdots | \vdots |
| λ_n | x_{n1} c_{n1} | \dots \dots | x_{nm} c_{nm} | s_n |
| | d_1 | \dots | d_m | |

Consider the Hitchcock transportation problem given by the following tableau:

| | | | | |
|--|---|---|---|---|
| | | | | 8 |
| | 5 | 3 | 4 | 6 |
| | 2 | 7 | 4 | 1 |
| | 5 | 6 | 2 | 4 |
| | 6 | 5 | 8 | 8 |

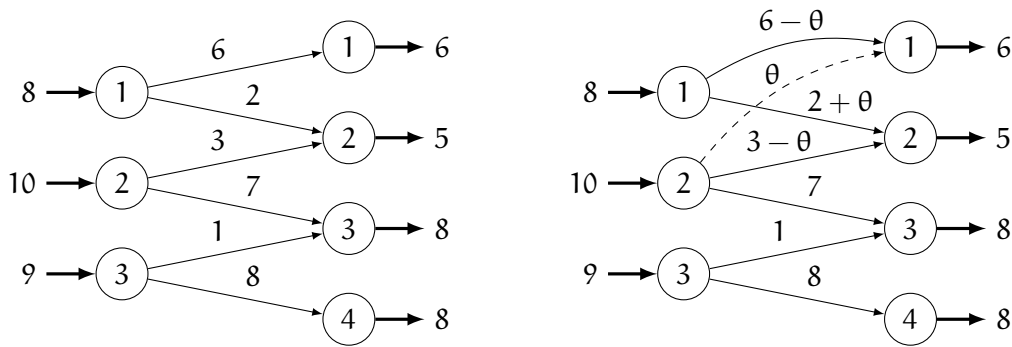

Figure 9.2: Initial basic feasible solution of a transportation problem (left) and a cycle along which the overall cost can be decreased (right)

An initial BFS can be found by iteratively considering pairs (i, j) of supplier i and customer j , increasing x_{ij} until either the supply s_i or the demand d_j is satisfied, and moving to the next supplier in the former case or to the next customer in the latter. Since $\sum_i s_i = \sum_j d_j$, this process is guaranteed to find a feasible solution, and the corresponding spanning tree consists of the pairs (i, j) that have been visited. If at some point both the supply and the demand are satisfied at the same time, the resulting solution is degenerate. In the example, we can start by setting $x_{11} = \min\{s_1, d_1\} = 6$, moving to customer 2 and setting $x_{12} = 2$, moving to supplier 2 and setting $x_{22} = 3$, and so forth. The resulting spanning tree and flows are shown on the left of Figure 9.2.

To determine the values of the dual variables λ_i for $i = 1, \dots, 3$ and μ_j for $j = 1, \dots, 4$, observe that $\lambda_i - \mu_j = c_{ij}$ must be satisfied for all $(i, j) \in T$. By setting $\lambda_1 = 0$, we obtain a system of 6 linear equalities with 6 variables, which has a unique solution. It will finally be convenient to write down $\lambda_i - \mu_j$ for $(i, j) \notin T$, which we do in the upper right corner of the respective cells. The tableau now looks as follows:

| | | | | | | | |
|---|---|----|----|---|----|---|----|
| | | -5 | -3 | 0 | -2 | | |
| 0 | 6 | 5 | 2 | 3 | 0 | 2 | 8 |
| | | 9 | 3 | 7 | 7 | 4 | 6 |
| 4 | 2 | 2 | 3 | 7 | 4 | 1 | 10 |
| | | 7 | 5 | 1 | 2 | 8 | |
| 2 | 5 | 5 | 6 | 1 | 2 | 4 | 9 |
| | | 6 | 5 | 8 | 8 | | |

If $c_{ij} \geq \lambda_i - \mu_j$ for all $(i, j) \notin T$, the current flow would be optimal. In our example this condition is violated, for example, for $i = 2$ and $j = 1$. Edge $(2, 1)$ forms a unique cycle with the spanning tree T , and we would like to increase x_{21} by pushing flow along this cycle. Due to the special structure of the network, doing so will alternately increase and decrease the flow for edges along the cycle. In particular, increasing x_{21} by θ will increase x_{12} and decrease x_{11} and x_{22} by the same amount. The situation is shown on the right of Figure 9.2. Increasing x_{21} by the maximum amount of $\theta = 3$ and re-computing the values of the dual variables λ_1 and μ_j , we obtain the following

tableau:

| | | | | | |
|----|---|----|----|----|----|
| | | -5 | -3 | -7 | -9 |
| 0 | 3 | 5 | 7 | 9 | |
| | 5 | 3 | 4 | 6 | |
| -3 | 3 | 0 | 7 | 6 | |
| | 2 | 7 | 4 | 1 | |
| -5 | 0 | -2 | 1 | 8 | |
| | 5 | 6 | 2 | 4 | |

Now, $c_{24} < \lambda_2 - \mu_4$, and we can increase x_{24} by 7 to obtain the following tableau, which satisfies $c_{ij} \geq \lambda_i - \mu_j$ for all $(i, j) \notin T$ and therefore yields an optimal solution:

| | | | | | |
|----|---|----|----|----|----|
| | | -5 | -3 | -2 | -4 |
| 0 | 3 | 5 | 2 | 4 | |
| | 5 | 3 | 4 | 6 | |
| -3 | 3 | 0 | -1 | 7 | |
| | 2 | 7 | 4 | 1 | |
| 0 | 5 | 3 | 8 | 1 | |
| | 5 | 6 | 2 | 4 | |

9.3 The Assignment Problem

An instance of the assignment problem is given by n agents and n jobs, and costs c_{ij} for assigning job j to agent i . The goal is to assign exactly one job to each agent at a minimum overall cost, i.e., to

$$\begin{aligned}
 &\text{minimize} && \sum_{i=1}^n \sum_{j=1}^n c_{ij} x_{ij} \\
 &\text{subject to} && x_{ij} \in \{0, 1\} \quad \text{for all } i, j = 1, \dots, n \\
 &&& \sum_{j=1}^n x_{ij} = 1 \quad \text{for all } i = 1, \dots, n \\
 &&& \sum_{i=1}^n x_{ij} = 1 \quad \text{for all } j = 1, \dots, n
 \end{aligned} \tag{9.1}$$

Except for the integrality constraints, this problem is a special case of the Hitchcock transportation problem. All basic solutions of the *LP relaxation* of this problem, which is obtained by replacing the integrality constraint $x_{ij} \in \{0, 1\}$ by $0 \leq x_{ij} \leq 1$, are spanning tree solutions and therefore integral. Thus, both the network simplex method and the general simplex method yield an optimal solution of the original problem when applied to the LP relaxation. This is not necessarily the case, for example, for the ellipsoid method.